

Use of the RCA-7587 Industrial Nuvistor Tetrode In RF and IF Applications

This Note discusses the use of the RCA-7587 nuvistor tetrode in small-signal high-frequency circuits. Input-admittance data are given for frequencies from 20 to 150 megacycles, and a small 60-megacycle wide-band amplifier is described.

Tube Design Features

The all-metal-and-ceramic RCA-7587 sharp-cutoff nuvistor tetrode uses a concentric cylindrical open-ended cantilever construction. The use of a top cap for the plate connection provides excellent input-to-output isolation, a low grid-No.1-to-plate capacitance of 0.01 micromicrofarad, and a low output capacitance of 1.4 micromicrofarads. In addition, the tube construction provides extremely low residual-gas currents, freedom from buildup of leakage paths, and a rugged internal structure. The low heater drain of 150 milliamperes, the high transconductance of 10,600 micromhos at 10 milliamperes of plate current, and its small size make the RCA-7587 particularly useful for general industrial and military application.

The bandwidth figure of merit GB for a tetrode is given by

$$GB = \frac{g_m}{2\pi (C_{in} + C_{out})}$$

The RCA-7587 has a cold input capacitance C_{in} of 6.5 micromicrofarads, a cold output capacitance C_{out} of 1.4 micromicrofarads, and a transconductance g_m of 10,600 micromhos. Substitution of these values in the above formula produces a nominal figure of merit of 214 megacycles. However, the input capacitance for a tube in a socket under operating conditions is approximately 9 micromicrofarads. Consequently, the actual figure of merit for an operating tube is 162 megacycles.

Input Admittance

When the current through a tube is varied, as it may be for the purpose of controlling the gain of an amplifier stage, variations in the input conductance and in the input capacitance affect the gain-vs-frequency characteristic of the circuit connected to the input of the tube.



Table I shows the values of short-circuit input capacitance and short-circuit input conductance of the RCA-7587 for conditions of normal operation, cutoff, and with the tube cold. These values were measured in a socket at a frequency of 60 megacycles. The capacitance values are nearly

Operating Condition	Input Capacitance ($\mu\mu\text{f}$)	Input Conductance (μmhos)
Tube operating ($I_b = 10 \text{ ma}$)	9.0	100
Tube cut off ($I_b = 0$)	7.7	18
Tube cold (no heater voltage applied)	7.1	17
Change from cutoff to $I_b = 10 \text{ ma}$	1.3	82
Change when heater voltage is applied	0.6	-

Table I - Variation of Short-Circuit Input Capacitance and Input Conductance of the RCA-7587 at 60 Megacycles.

independent of frequency up to approximately 150 megacycles. Theoretical considerations indicate that the conductance should increase with the square of the frequency. The measured data shown in the curve of Fig.1 indicate a somewhat more rapid increase with frequency. This difference results from the series inductance in the measurement circuit.

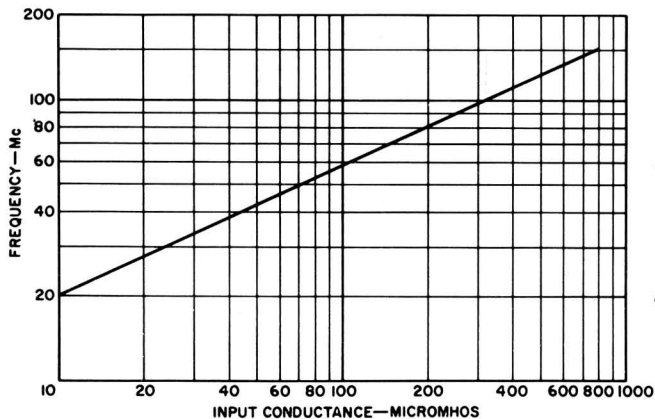

Fig.1 - Relationship between operating frequency and input conductance of RCA-7587 at typical operating conditions ($g_m = 10,600 \mu\text{mhos}$; $I_b = 10 \text{ ma}$).

The variation of input capacitance and input conductance with operating conditions can be reduced substantially if the tube is used in a circuit which includes an unbypassed cathode resistor. Figs.2 and 3 show data for the 7587 measured in such a circuit. As shown in Fig.2, the value of unbypassed cathode resistance which provides minimum change in capacitance between cutoff and maximum transconductance is about 18 ohms. The value which provides minimum change in conductance is about 33 ohms, as shown in Fig.3. The circuit designer should select a resistance value between these limits which will have the smallest effect on the bandpass characteristic of his particular system.



The data shown in Figs.2 and 3 were measured at a frequency of 60 megacycles. The choice of resistance values for optimum results is not affected appreciably by changes in frequency, but the magnitude of the conductance values varies approximately with the square of the frequency, as mentioned previously.

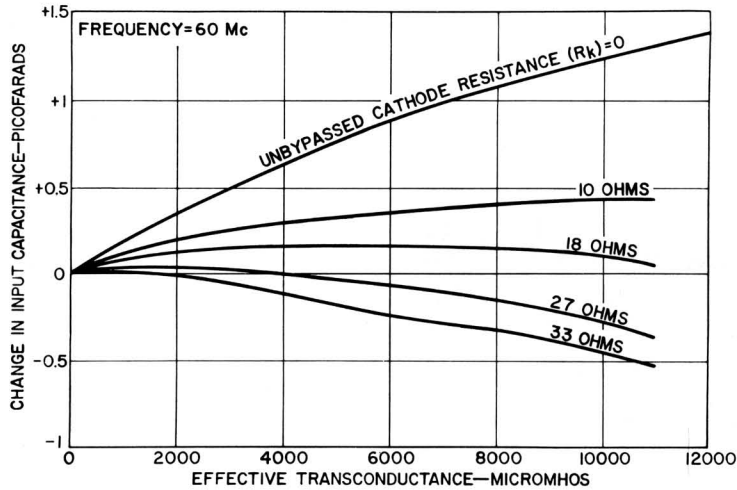

Fig.2 - Variation of short-circuit input capacitance at 60 megacycles as a function of transconductance for several values of unbypassed cathode resistance.

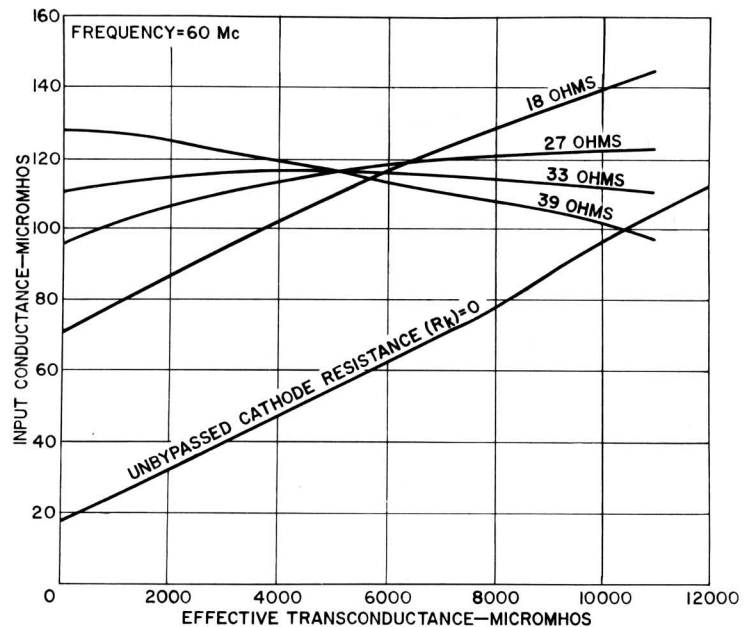

Fig.3 - Variation of short-circuit input conductance at 60 megacycles as a function of transconductance for several values of unbypassed cathode resistance.

The amount of unbypassed cathode resistance needed to minimize the variation of capacitance and conductance with operating conditions is less than the total value of cathode resistance suggested in the published "typical operating conditions" for the 7587. Consequently, either an additional bypassed section of cathode resistor or an external source of bias is required. In high-gain circuits with automatic gain control, the



initial biasing voltage developed from noise in the system under small-signal conditions is often sufficient to supply enough initial bias to prevent excessive plate and screen-grid currents.

IF Amplifier Design

The simple five-stage 60-megacycle if amplifier shown in Fig.4 demonstrates the capabilities of the 7587. This amplifier consists of staggered single-tuned stages (a flat-staggered quintuple¹), and has a bandwidth of 8 megacycles.

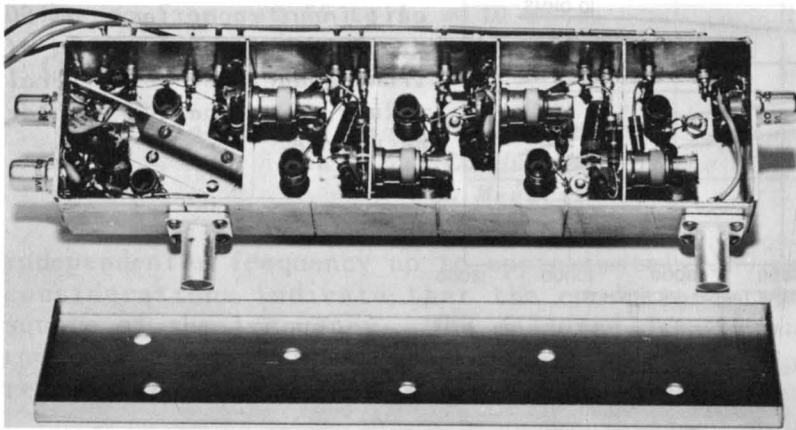

Fig.4 - Photograph of an experimental 5-stage 60-megacycle if amplifier using RCA-7587.

As shown in Fig.5, the first stage consists of two RCA-7586 nuvistor triodes in cascode arrangement, followed by four 7587 nuvistor tetrodes and a diode-connected 7586 triode used as a detector. The cascode input stage was chosen to take advantage of the low noise figure inherent in this configuration. The tetrodes are single-tuned and staggered. The first two tetrodes V_3 and V_4 are gain-controlled. Unbypassed cathode resistors are mandatory to preserve the proper shape of the bandpass characteristic as the gain is varied. V_5 and V_6 have fixed gain; however, small unbypassed resistors have been added to provide some degeneration to improve stability.

The damping of each tuned circuit in a stagger-tuned amplifier is dependent upon the individual bandwidth and frequency required to achieve an over-all flat bandpass of desired width. In this amplifier, the plate-load resistor of the preceding stage and the input conductance of the tuned grid-No.1 circuit are placed in parallel to achieve the proper bandpass. The value of damping resistance calculated for each stage can be only a first approximation because the short-circuit input-conductance data do not show the input-conductance component resulting from feedback through the grid-No.1-to-plate capacitance. This feedback component, when measured at the grid-No.1-circuit resonant frequency, is positive when the plate circuit is tuned to a frequency lower than that of the grid-No.1 circuit and negative when the plate circuit is tuned to a frequency higher than that of the grid-No.1 circuit.

¹ G. E. Valley, Jr. and H. Wallman, *Vacuum-Tube Amplifiers*, 1st Ed., McGraw-Hill Book Company, Inc., New York, N. Y., 1948, pp.180-186.



Each stage is tuned by adjustment of its inductance for resonance with the tube and stray circuit capacitance. Because of the uniformity of nu-vistor characteristics from tube to tube, a minimum amount of adjustment is necessary to retain the proper bandpass characteristics when tubes are interchanged.

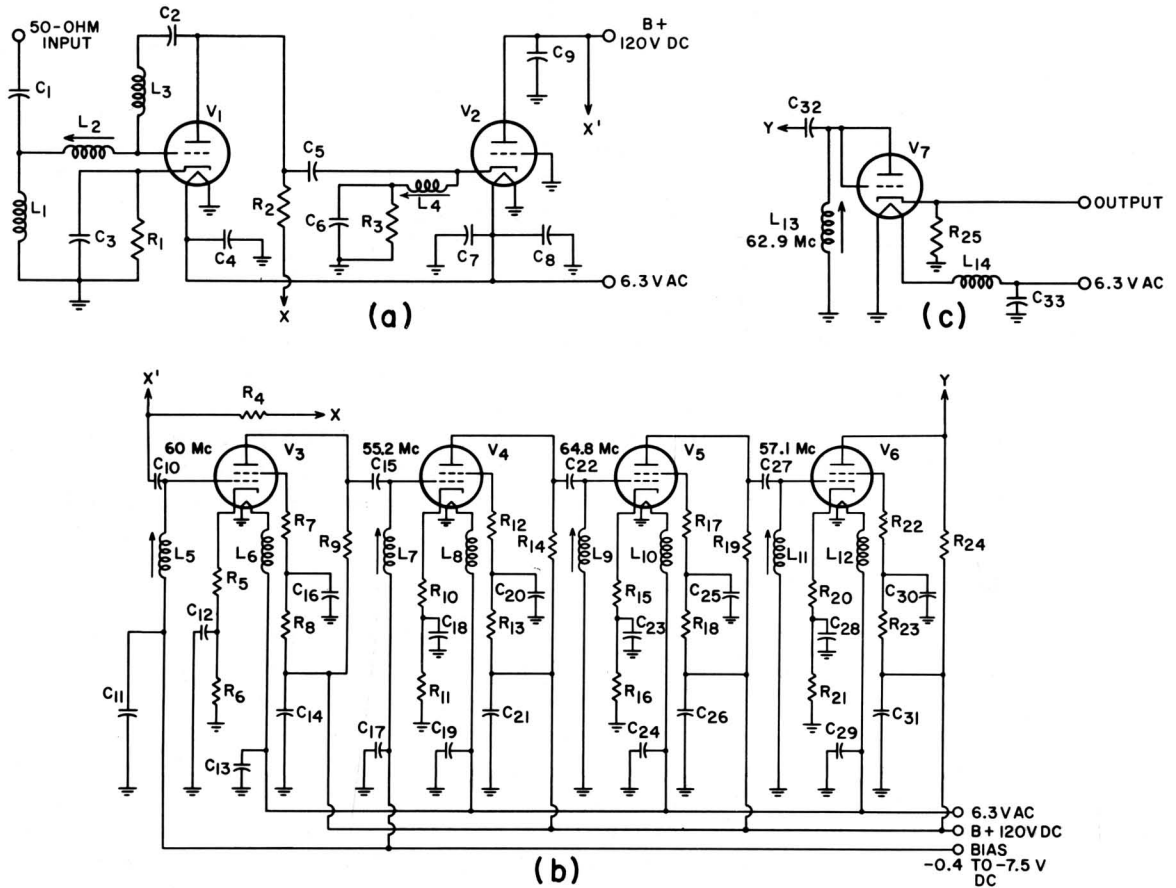

- $C_1 C_2 C_5 C_{10} C_{15} C_{22} C_{27} C_{32} = 390 \mu\mu f$
- $C_3 C_4 C_6 C_8 C_{12} C_{16} C_{18} C_{20} C_{23} C_{25}$
- $C_{28} C_{30} = 500 \mu\mu f$
- $C_7 C_9 C_{11} C_{13} C_{14} C_{17} C_{19} C_{21} C_{24} C_{26}$
- $C_{29} C_{31} C_{33} = 1000 \mu\mu f$, feedthrough
- $L_1 = 4.8 \mu h$
- $L_2 L_4 = 0.5 \mu h$, ferrite core
- $L_3 L_6 L_8 L_{10} L_{12} L_{14} = 5 \mu h$
- $L_5 L_9 L_{13} = 8$ turns No.24 AWG close-wound on 1/4-inch round form (ferrite core)
- $L_7 L_{11} = 9$ turns No.24 AWG close-wound on 1/4-inch round form (ferrite core)
- $R_1 = 150$ ohms

- $R_2 R_{14} = 4700$ ohms
- $R_3 = 220$ ohms
- $R_4 R_{24} = 1800$ ohms
- $R_5 R_{10} = 27$ ohms
- $R_6 R_{11} = 39$ ohms
- $R_7 R_{12} R_{17} R_{22} = 10$ ohms
- $R_8 R_{13} R_{18} R_{23} = 27000$ ohms
- $R_9 = 6200$ ohms
- $R_{15} R_{20} = 18$ ohms
- $R_{16} = 47$ ohms
- $R_{19} = 2200$ ohms
- $R_{21} = 68$ ohms
- $R_{25} = 18000$ ohms

Fig.5 - Schematic diagram for amplifier shown in Fig.4: (a) 7586 preamplifier; (b) 7587 IF amplifier; (c) 7586 detector used for measurements.



The effective grid-No.1-to-plate capacitance of an rf amplifier tube is much higher than the value measured at low frequencies if the screen grid is not at rf ground potential. It becomes difficult to ground the screen grid effectively at frequencies above 30 megacycles because of the inductance of the screen-grid and bypass-capacitor leads. Unbypassed 10-ohm series resistors were used to "swamp out" any possible high-Q series resonances that might be caused by the bypass capacitor. The lead inductances can be adjusted to resonate in series with the bypass capacitor to effectively ground the screen grid.

The small size and double-ended construction of the 7587 simplify the circuit layout because the chassis can be made to act as a physical barrier between input and output. Experience has shown that high packaging densities (small over-all size) can be readily achieved with negligible instability provided proper bypassing and decoupling are used. The basic amplifier chassis shown in Fig.4 measures 1-7/8 inches by 1-1/4 inches by 7-5/8 inches. The over-all length is increased slightly to 8-1/4 inches when the cascode 7586 nuvistors are inserted in one end. This unit is not as small as possible; other units using more tubes have been built even more compactly.² In this circuit, however, each stage was "compartmentalized" to minimize the external feedback paths by taking advantage of the double-ended feature of the 7587. The plate, bias, and heater-voltage supply or bus lines are strung "outboard" along one side of the chassis.

Gain and Bandpass Measurements

The over-all amplifier gain of the circuit shown in Fig.5 was measured with a 60-megacycle unmodulated signal applied to the input grid of the first stage. A dc voltmeter was connected across the detector load resistor and an rf vacuum-tube voltmeter was connected across the tuned inductance in the detector plate circuit. With the signal on, both rf and dc voltages were measured. The rf meter was then removed, and the level of the input signal was adjusted until the original dc voltage was obtained across the detector load. The rf output voltage was then divided by the adjusted input-signal voltage to calculate the over-all gain. The voltage gain of the 60-megacycle amplifier was 104,000; the average gain per stage was greater than 10.

For measurement of the bandpass characteristics of the amplifier, the input-signal level was varied to maintain a constant dc voltage across the detector load throughout the passband. Fig.6 shows the gain-bandpass characteristics of the amplifier of Fig.5 for gains of 705, 11,100, and 104,000.

Maximum Operating Temperature

Good design practice for reliability and life requires consideration of the maximum operating-temperature ratings for all components. The 7587 can operate at a maximum shell temperature of 150 degrees centigrade, measured at the gussets near the base of the tube. The 150-degree limitation permits chassis temperatures of up to 75 degrees centigrade at full dissipation. Temperature measurements are made with a small thermocouple welded

² "Nuvistors Improve Performance of Beacon IF Strip", 'ELECTRICAL DESIGN NEWS, Vol.5, No.8, August 1960, p.34.



to a gusset of the nuvistor. The weld can be made by discharging a capacitor through the junction of the thermocouple and the tube shell. A 200-microfarad capacitor charged to about 75 volts welds a thermocouple wire having a diameter of 0.005 inch.

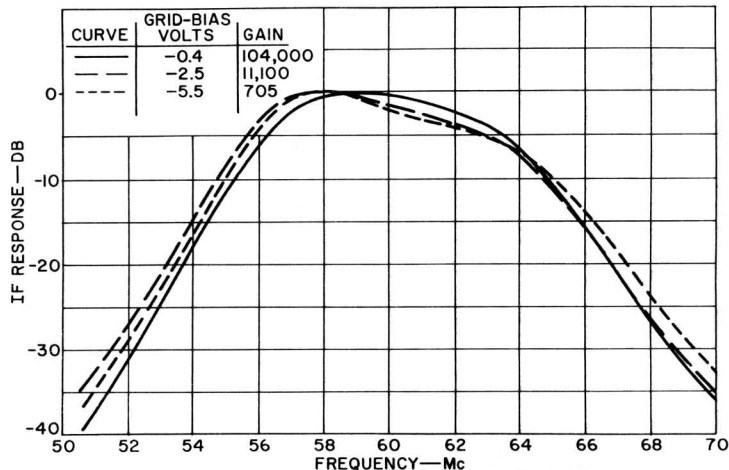

Fig. 6 - Gain-bandpass characteristics of amplifier shown in Figs. 4 and 5.

The 7587 is designed so that the metal shell, particularly the lug contact to the socket, conducts heat away from the tube. When printed-board or other poor-heat-conducting materials are used for the chassis, care should be taken to insure that the tube-shell temperature does not exceed 150 degrees centigrade. Operation at higher temperatures may increase grid current and impair the life of the tube. When the tubes are used at full dissipation on a printed board, the metallic portion of the chassis should be connected to a suitable heat sink.

Information furnished by RCA is believed to be accurate and reliable. However, no responsibility is assumed by RCA for its use; nor for any infringements of patents or other rights of third parties which may result from its use. No license is granted by implication or otherwise under any patent or patent rights of RCA.

